



Ship's particulars



M/V 'FREDENSBORG'

Valid as of 09 Oct 2023

Registration	
Call sign	HSB4733
IMO number	9465394
Port of registry	Bankok
Flag state	Thailand
Shipyard	Sanfu Shipyard
Year/Place of delivery	2011/PRC
Class	Rina
Class notation	C ✕ General Cargo ship Double side-skin, unrest. Nav. ✕ AUT-UMS, BWM-E – flow- Through, Grabloading, Ice class IA, Inwatersurvey
P&I Club	Standard Club Ireland DAC
Tonnage	
DWAT	12.767 mt (summer dw)
DWCC	Abt. 11.800 mt
Gross tonnage	9.627
Net tonnage	4.261
Dimensions	
Length over all	138,53 m
Length between p.p.	130,71 m
Breadth over all	21,00 m
Breadth moulded	21,00 m
Summer draught	8,00 m
Depth moulded	11,00 m
Height keel to top mast	39,38 m
Hold/hatch sizes	
Number of holds/hatches	3/3
Hold capacity	About 15.953 m ³ /563.375 ft ³
#1 Hatch coaming/Lower hold	18,72 x 15,00/10,00 m
#2 Hatch coaming/Lower hold	42,00 x 17,50 m
#3 Hatch coaming/Lower hold	25,50 x 17,50/14,60 m
Weather deck dimensions	104,05 x 17,50 m
#1, #2 and #3 Hold heights	10,75/11,40/10,99 m
#1 Heights above/below T/D	4,55/5,40 m
#2 Heights above/below T/D	7,05/3,55 m or 4,43/5,97 m or 2,98/7,42 m
#3 Heights above/below T/D	4,43/5,56 m
Loading area under deck	2.856 m ²
Loading area on deck	1.463 m ²
Container capacity	
Hold capacity	334 TEU
Deck capacity	331 TEU (50 reefer)
Total	665 TEU
Stack weight TEU/FEU	Tank top: 96/120 mt Hatch covers: 50/65 mt
TEU slots for IMO class 1.1-1.6	On hatches and hold #1
1.4S	All deck and holds

Deck loads	
Tank top	16,0 mt/m ²
#1 + #2 upper tween deck	2,5 mt/m ²
#2 lower/mid tween deck	4,0 mt/m ²
#3 hold	4,0 mt/m ²
Hatch covers	1,75 mt/m ²
Hatch covers/Tween deck	
Type of hatch covers	18 hydr./foldable covers
Tween deck pontoons	3+7+4 = 14 removable panels
Grain bulkheads made of tween deck panels	2 positions in hold #2
Propulsion/Manoeuvring	
Main Engine	5400 kW
Bow thruster	500 kW
Shaft generator	760 kW
Propeller	Balanced
Rudder	Controllable Pitch Propeller
Service speed	15,0 kn
Bunkers/Ballast capacity	
Heavy fuel oil	955 m ³
Marine gas oil	152 m ³
Fresh water	148 m ³
Ballast water	4.932 m ³
Cargo gear	
Cranes on port side	2 x NMF x 150 mt SWL
Load/Outreach	150 mt/4,5 – 16,0 m 120 mt/4,5 – 19,0 m 95 mt/4,0 – 24,0 m 70 mt/3,5 – 33,0 m
Tandem load	300 mt SWL
Lifting beam on board	1 x 18 mtr, 2 x 150 mt WLL 1 x 12 mtr, 300 mt WLL
Spreader beams on board	2 x 3.2-5.2 mtr, 165 mt WLL 2 x 6,2-8,2 mtr, 165 mt WLL
Lifting heights	

*All details are believed to be correct but
without guarantee/HWS*

Phone: +45 7070 1311
E-mail: europe@ocean7projects.com
Web: ocean7projects.com

SIDE VIEW

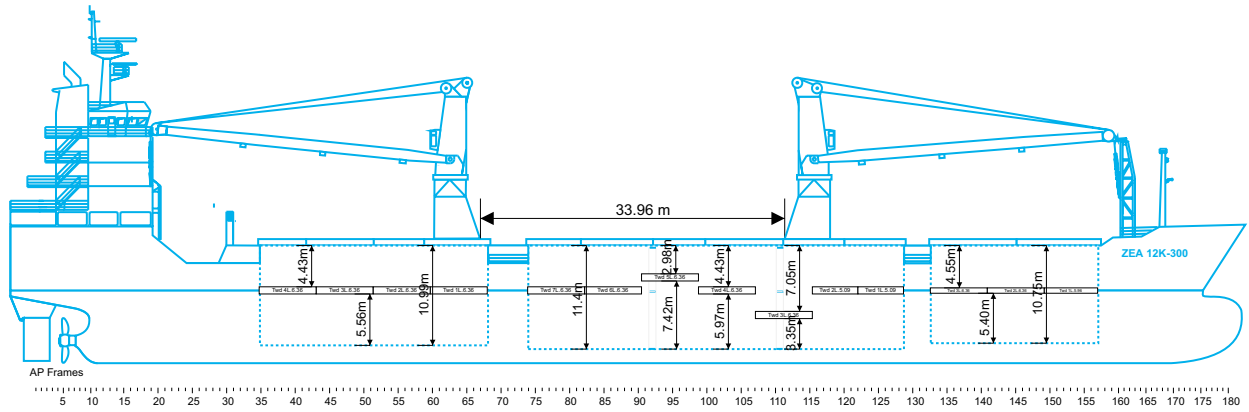

MAIN DECK

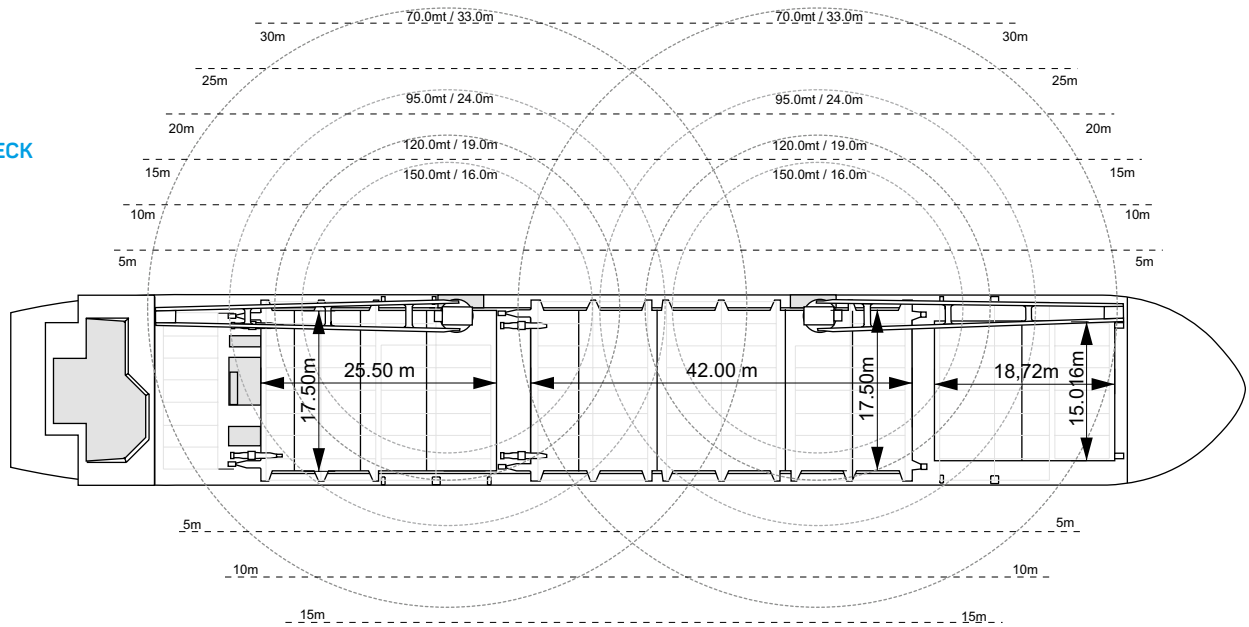

TWEENDECK

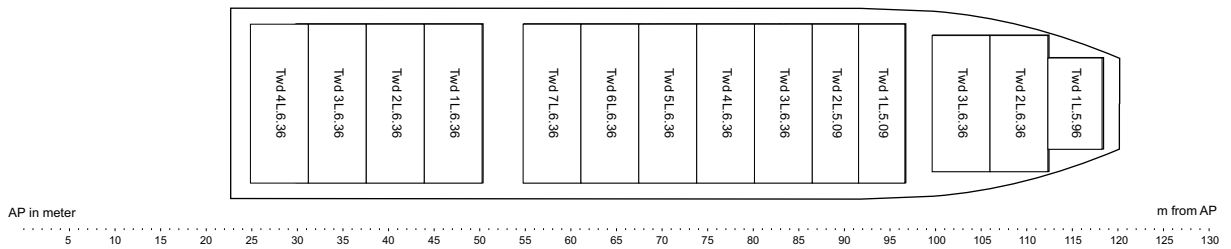

HOLDS & DOUBLE BOTTOM

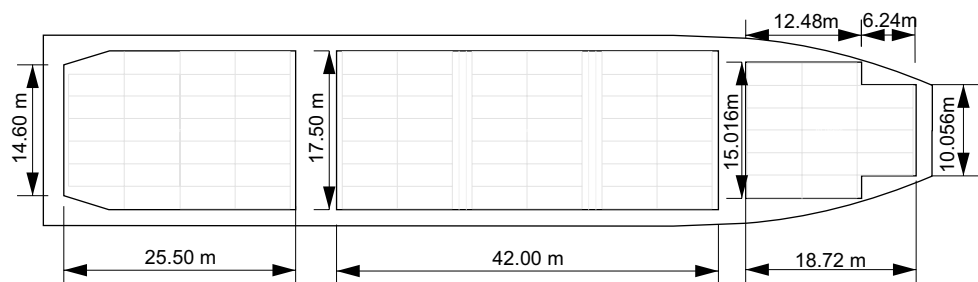

27	25	23	21	19	17	15	13	11	09	07	05	03	01
	24		20		16		12		08		04	02	

BAY NO. (20'CONT.)
BAY NO. (40'CONT.)

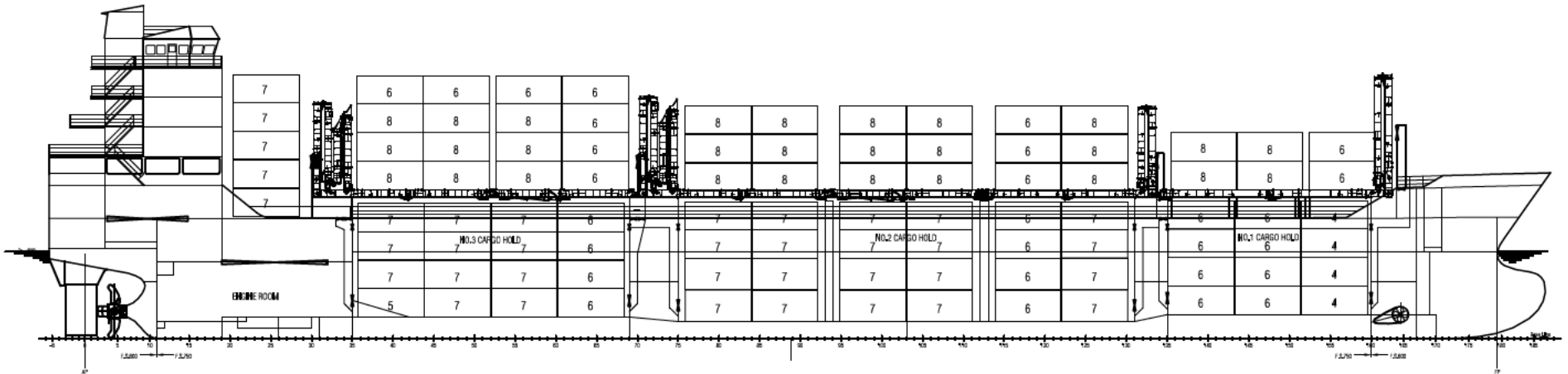

35	30	30	30	24	24	24	24	18	24	16	16	12
	30		24(6)		24		24		24		16	
	26	28	28	24	28	28	28	24	28	24	24	16
	26(2)		24		28	28	28		28	24	16(8)	

DECK 20' TOTAL TEU 331
DECK 40' TOTAL FEU 142 (6)

HOLD 20' TOTAL TEU 334
HOLD 40' TOTAL FEU gr2 158 (18)
HOLD 40' TOTAL FEU gr1 150 (34)

TOTAL TEU 665
TOTAL FEU 300 (24)

