



M/V 'FREDENSBORG'

Valid as of 22 Oct 2024

Registration	
Call sign	HSB4733
IMO number	9465394
Port of registry	Bankok
Flag state	Thailand
Shipyard	Sanfu Shipyard
Year/Place of delivery	2011/PRC
Class	Rina
Class notation	C ✕ General Cargo ship Double side-skin, unrest. Nav. ✕ AUT-UMS, BWM-E – flow- Through, Grabloading, Ice class IA, Inwatersurvey
P&I Club	Standard Club Ireland DAC
Tonnage	
DWAT	12.767 mt (summer dw)
DWCC	Abt. 11.800 mt
Gross tonnage	9.627
Net tonnage	4.261
Dimensions	
Length over all	138,53 m
Length between p.p.	130,71 m
Breadth over all	21,00 m
Breadth moulded	21,00 m
Summer draught	8,00 m
Depth moulded	11,00 m
Height keel to top mast	39,38 m
Hold/hatch sizes	
Number of holds/hatches	3/3
Hold capacity	About 15.953 m ³ /563.375 ft ³
#1 Hatch coaming/Lower hold	18,72 x 15,00/10,00 m
#2 Hatch coaming/Lower hold	42,00 x 17,50 m
#3 Hatch coaming/Lower hold	25,50 x 17,50/14,60 m
Weather deck dimensions	104,05 x 17,50 m
#1, #2 and #3 Hold heights	10,75/11,40/10,99 m
#1 Heights above/below T/D	4,55/5,40 m
#2 Heights above/below T/D	7,05/3,55 m or 4,43/5,97 m or 2,98/7,42 m
#3 Heights above/below T/D	4,43/5,56 m
Loading area under deck	2.856 m ²
Loading area on deck	1.463 m ²
Container capacity	
Hold capacity	334 TEU
Deck capacity	331 TEU (50 reefer)
Total	665 TEU
Stack weight TEU/FEU	Tank top: 96/120 mt Hatch covers: 50/65 mt
TEU slots for IMO class 1.1-1.6	On hatches and hold #1
1.4S	All deck and holds

Deck loads	
Tank top	16,0 mt/m ²
#1 + #2 upper tween deck	2,5 mt/m ²
#2 lower/mid tween deck	4,0 mt/m ²
#3 hold	4,0 mt/m ²
Hatch covers	1,75 mt/m ²
Hatch covers/Tween deck	
Type of hatch covers	18 hydr./foldable covers
Tween deck pontoons	3+7+4 = 14 removable panels
Grain bulkheads made of tween deck panels	2 positions in hold #2
Propulsion/Manoeuvring	
Main Engine	5400 kW
Bow thruster	500 kW
Shaft generator	760 kW
Propeller	Balanced
Rudder	Controllable Pitch Propeller
Service speed	15,0 kn
Bunkers/Ballast capacity	
Heavy fuel oil	955 m ³
Marine gas oil	152 m ³
Fresh water	148 m ³
Ballast water	4.932 m ³
Cargo gear	
Cranes on port side	2 x NMF x 150 mt SWL
Load/Outreach	150 mt/4,5 – 16,0 m 120 mt/4,5 – 19,0 m 95 mt/4,0 – 24,0 m 70 mt/3,5 – 33,0 m
Tandem load	300 mt SWL
Lifting beam on board	1 x 18 mtr, 2 x 150 mt WLL 1 x 12 mtr, 300 mt WLL
Spreader beams on board	2 x 3.2-5.2 mtr, 165 mt WLL 2 x 6,2-8,2 mtr, 165 mt WLL

Lifting heights

*All details are believed to be correct but
without guarantee/HWS*

Phone: +45 7070 1311
E-mail: europe@ocean7projects.com
Web: ocean7projects.com

SIDE VIEW

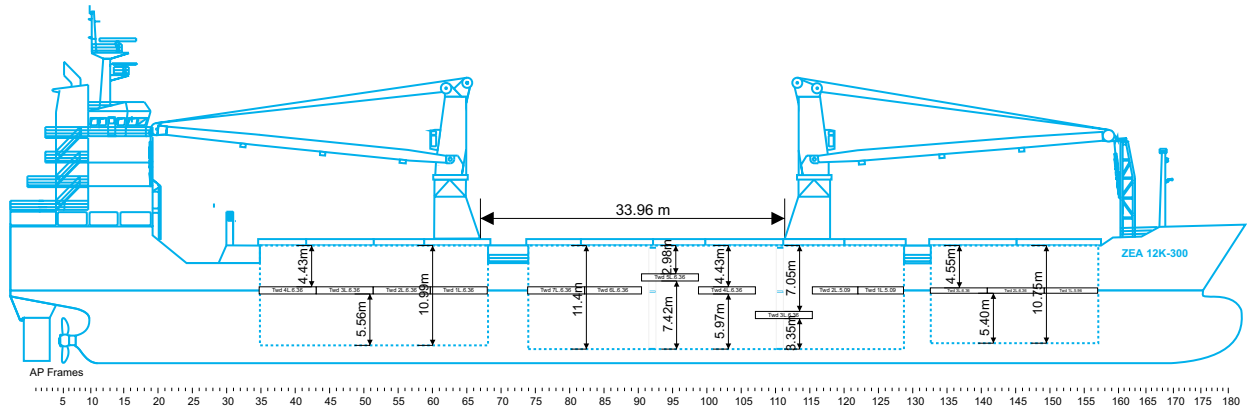

MAIN DECK

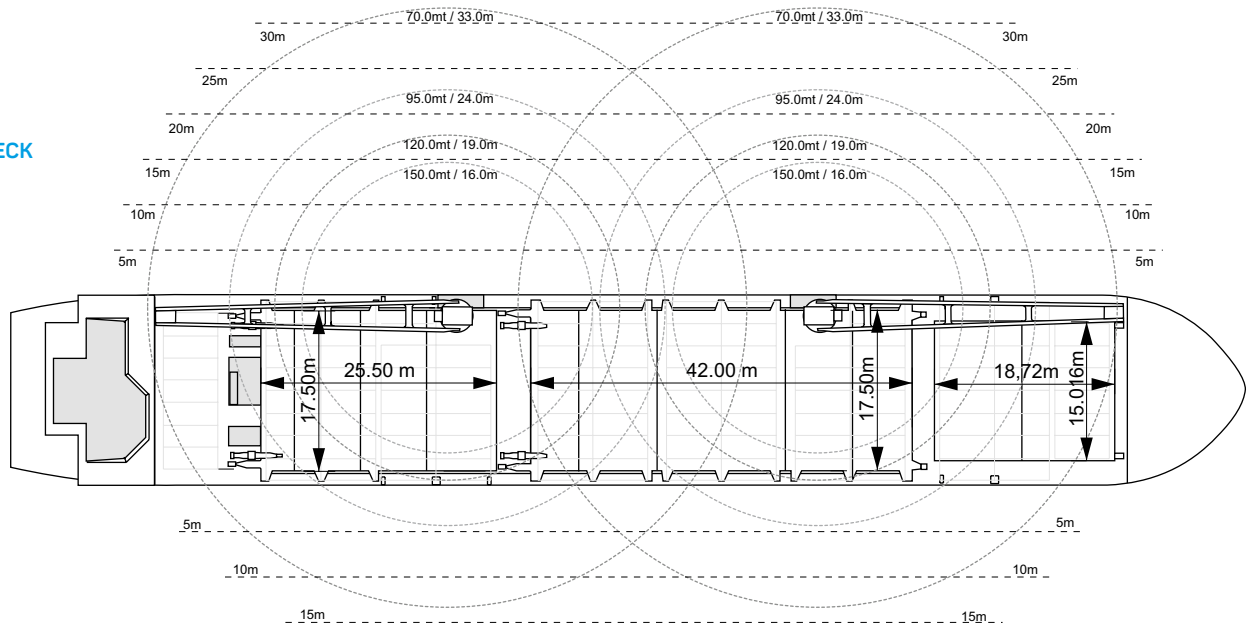

TWEENDECK

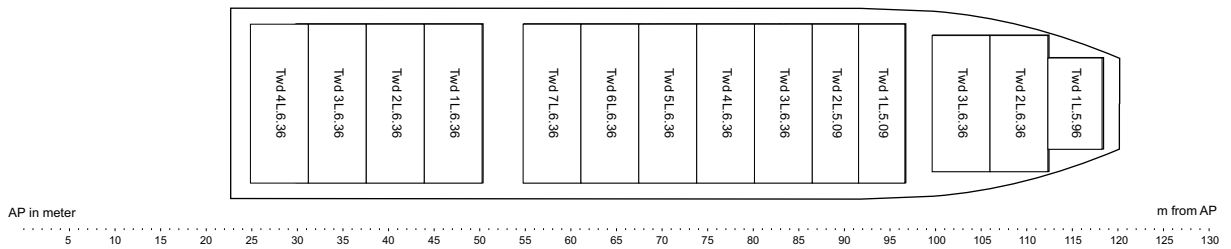

HOLDS & DOUBLE BOTTOM

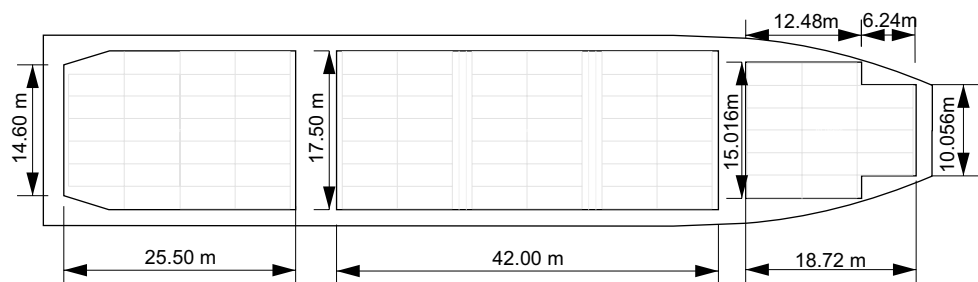

Fredensborg

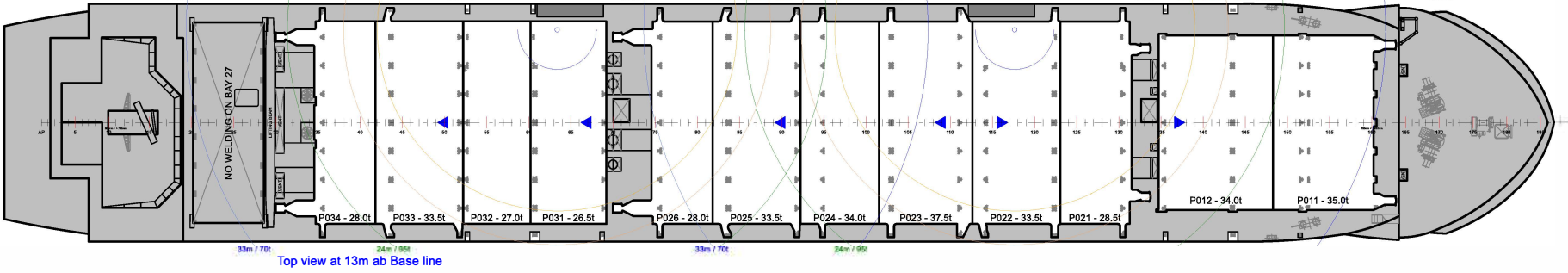
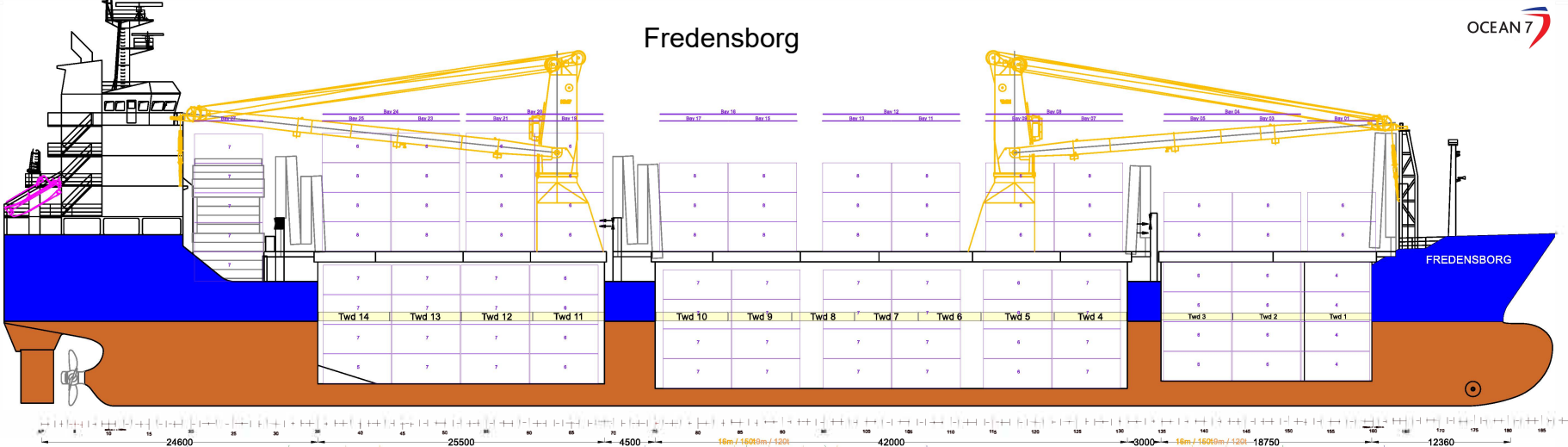

Top view at 13m ab Base line

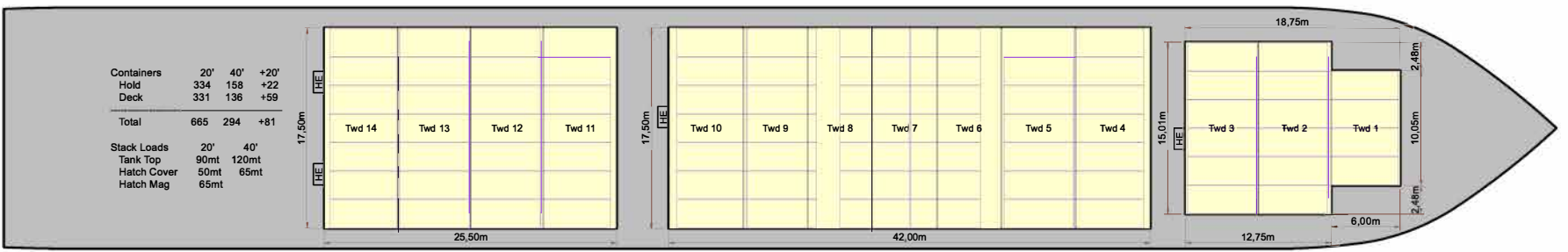

Top view at 9m ab Base line

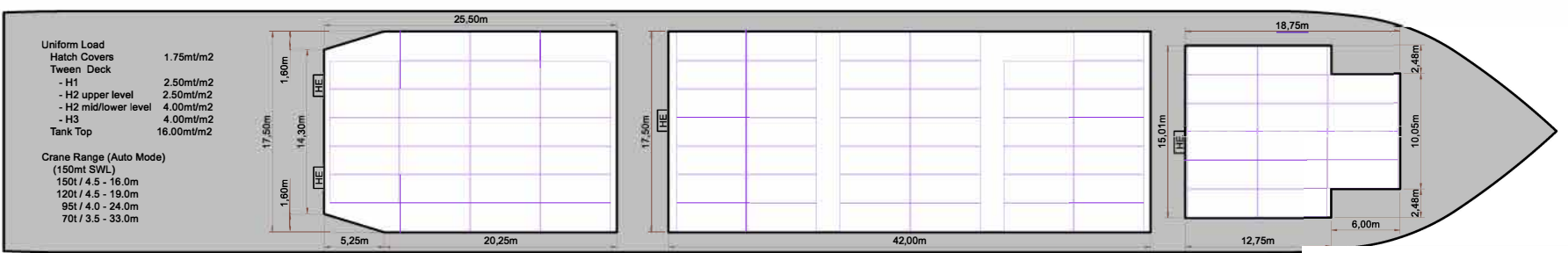

Top view at 3m ab Base line

