

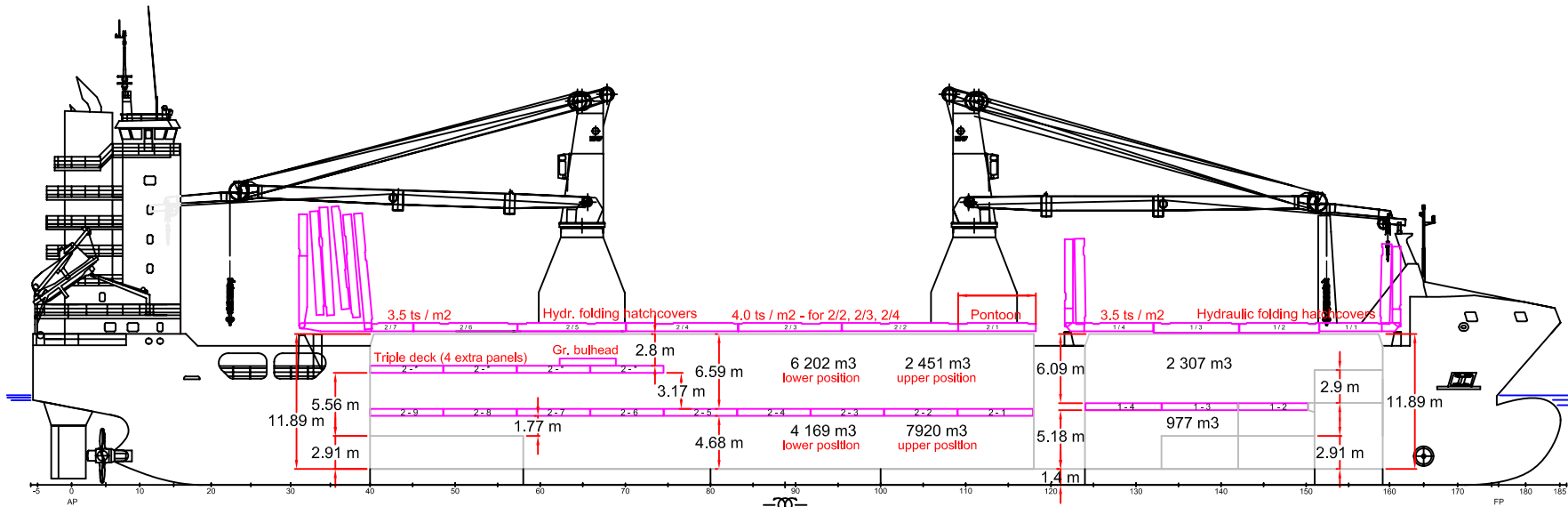

M/V 'HR REVOLUTION'

<p>Class DNV-GL Class notation I ⊗ 100 A5 Multi-Purpose DC-ship Equipped for carriage of cont. DBC SOLAS-II-2, Reg.19 ERS IW Strengthened for heavy cargo ⊗ MC AUT</p> <p>P&I Club Skuld</p> <p>Tonnage Displacement 15550 mt DWAT 9992 mt (incl. Tween decks) DWCC Abt. 9000 mt Gross tonnage 8963 Net tonnage 4522</p> <p>Dimensions Length over all 134,65 m Length between p.p. 125,60 m Breadth over all 21,50 m Breadth moulded 21,50 m Summer draught 7,95 m Depth moulded 9.30 m Height keel to top mast 40,80 m</p> <p>Hold/hatch sizes Number of holds/hatches 2/2 Hold capacities About 13.875 m³/489.995 ft³ #1 Lower hold dimensions 20,25 x 13,00/7,80/5,20 m #1 Tween deck dimensions 20,25 x 13,00/7,80 m #1 Hatch dimensions 25,50 x 16,90/13,00 m #1 Tank top -> TWD -> HC 5,18 / 6,09 m #2 Lower hold dimensions 58,50 x 16,90/5,20(aft 13.5m) #2 Tween deck dimensions 58,50 x 16,90 m #2 Hatch dimensions 57,98 x 16,90 m #2 Tank top -> TWD -> HC 4,68/6,59 or 8,47/2,80 m Weather deck dimensions 89,25 x 17,3 m Hold height 11,89 m</p> <p>Hatch cover surface 1.413 m² Tween deck surface 1.736 m² Lower hold surface 1.006 m²</p> <p>Container capacity Hold capacity 252 TEU Deck capacity 295 TEU (10 Reefer) Total 547 TEU (464 TEU @ 14 mt)</p> <p>Stack weight TEU/FEU Tank top: 90/120 mt Hatch cover: 40/60 mt</p> <p>TEU slots for IMO class 1 All on deck, class 1.4S in holds</p>	<p>Deck loads Tanktop 15.0 mt/m² Tween deck pontoons 3.0 mt/m² Hatch covers (HC) 3,5 mt/m² HC between cranes 4,0 mt/m²</p> <p>Hatch cover/Tween deck Type of hatch covers Hydraulic folding + pontoons Tween deck pontoons 17 removable pontoons (can be used as bulkheads)</p> <p>Propulsion/Manoeuvring Main Engine 7.200 kW Bow thruster 650 kW Propeller Variable pitch propeller Rudder Free-hanging flap type Service speed 13,75 kn</p> <p>Bunkers/Ballast capacity Heavy fuel oil 719 m³ Marine gas oil 318 m³ Lubricating oil 29 m³ Fresh water 136 m³ Ballast water 5843 m³</p> <p>Cargo gear Cranes on port side 2 x NMF 250 mt SWL Load/Outreach 250 mt/6,5-12,0 m 200 mt/5,5-15,0 m 150 mt/5.5-20,0 m 100 mt/4,0-30,0 m 35 mt/3,0-30,0 m Tandem operation 500 mt SWL</p> <p>Lifting beam on board 1 x 18,0 m, WLL 460 mt Spreader beams on board 1 x 11,6 m, WLL 250 mt 2 x 1,0/2,0/3,0/4,0/5,0/6,0 m (14 in total) WLL 250 mt</p> <p>Lifting heights At 6,5 m outreach 34,0 m At 12,0 m outreach 33,0 m At 15,0 m outreach 31,6 m At 20,0 m outreach 28,2 m At 30,0 m outreach 12,4 m</p> <p><i>All details are believed to be correct but without guarantee.</i></p> <p>OCEAN7 Projects ApS Jyllandsgade 19A DK-7000 Fredericia Denmark</p> <p>Phone: +45 7070 1311 E-mail: denmark@ocean7projects.com</p>
--	--



Capacity incl. Twd: 10 371 m³
excl. Twd: 11 305 m³

Capacity incl. Twd: 3 284 m³
excl. Twd: 3 428 m³

TWEEN DECKS

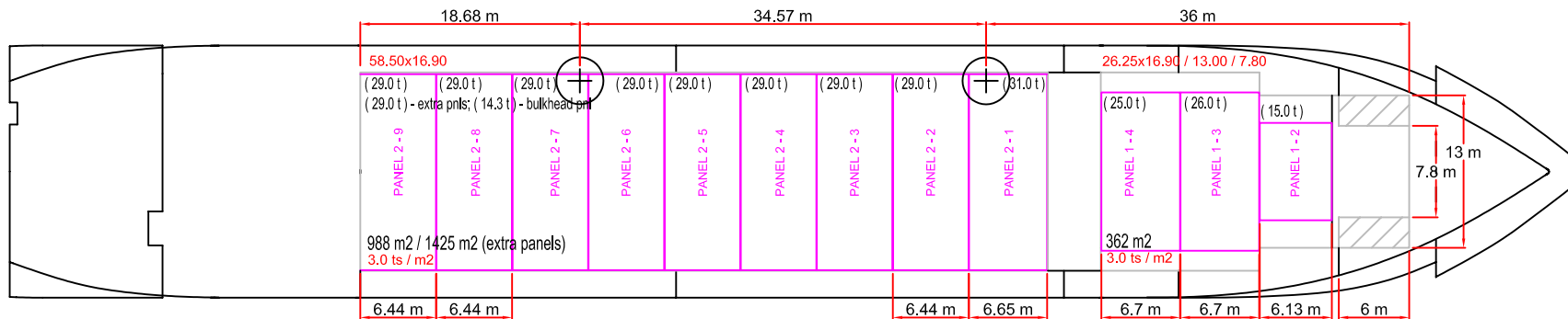

TANKTOP

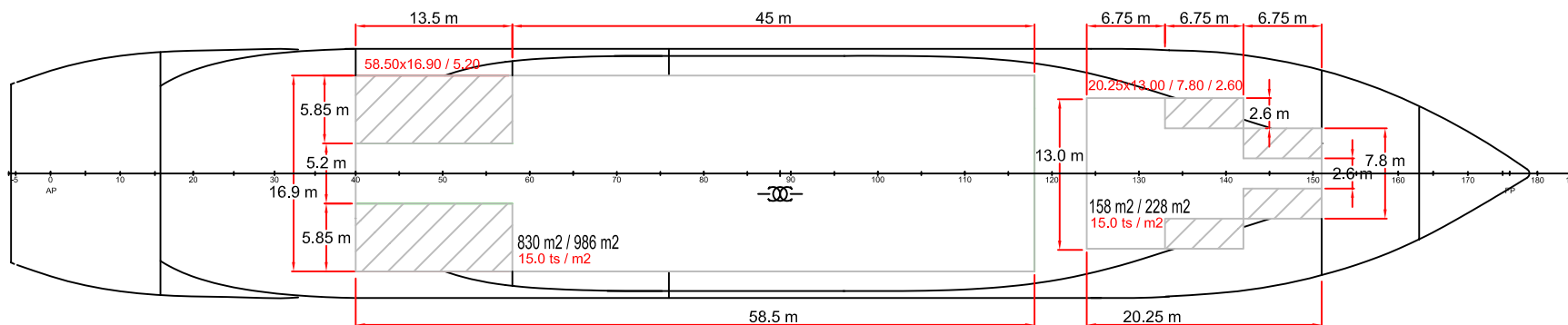

CONTAINER ARRANGEMENT

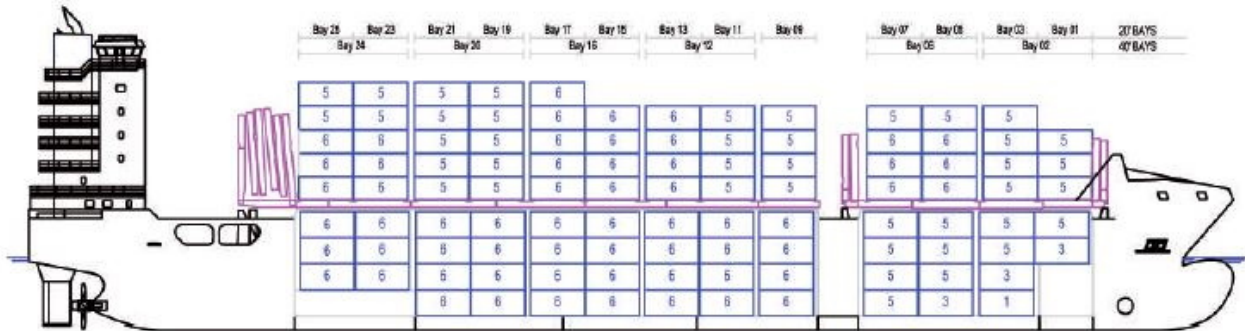

LIFTING DIAGRAM

CRANE No.1,2 SWL 250 mt

