

## M/V 'INDUSTRIAL RUBY'

Valid as of 27 Dec 2023

<p><b>Registration</b>  Call sign D5AH3  IMO number 9277292  Port of registry Monrovia  Flag state Liberia  Shipyard Volharding Shipyards  Year/Place of delivery 2005/Hoogezand  Class DNV-GL  Class notation I ✕100 A5 Multi-Purpose  DC-ship Equipped for carriage of cont. DBC SOLAS-II-2, Reg.19 ERS IW Strengthened for heavy cargo ✕MC AUT  P&amp;I Club Skuld</p> <p><b>Tonnage</b>  DWAT 10.581 mt (incl. Tween decks)  DWCC Abt. 9500 mt  Gross tonnage 8963  Net tonnage 4522</p> <p><b>Dimensions</b>  Length over all 134,52 m  Length between p.p. 125,67 m  Breadth over all 21,50 m  Breadth moulded 21,50 m  Summer draught 7,95 m  Depth moulded 9,30 m  Height keel to top mast 42,20 m</p> <p><b>Hold/hatch sizes</b>  Number of holds/hatches 2/2  Hold capacities About 13.875 m<sup>3</sup>/489.995 ft<sup>3</sup>  #1 Hatch cover 26,26 x 17,38 m  #1 Hatch opening 25,50 x 16,90 m  #1 Tween deck 20,25 x 13,00/7,80 m  #1 Lower hold 20,25 x 13,00/7,80/5,20 m  #2 Hatch cover 58,50 x 17,30 m  #2 Hatch opening 57,98 x 16,90 m  #2 Tween deck 58,50 x 16,90 m  #2 Lower hold 58,50 x 16,90/5,20 m  #1 Tween deck above/under 6,09/5,18 m  #2 Tween decks above/under 2,80/8,47 or 6,59/4,68 m  Hold height 11,89 m</p> <p>Hatch cover surface 1.413 m<sup>2</sup>  Tween deck surface 1.736 m<sup>2</sup>  Lower hold surface 1.006 m<sup>2</sup></p> <p><b>Container capacity</b>  Hold capacity 252 TEU  Deck capacity 295 TEU (10 Reefer)  Total 547 TEU (464 TEU @ 14 mt)</p> <p>Stack weight TEU/FEU Tank top: 90/120 mt  Hatch cover: 40/60 mt</p> <p>TEU slots for IMO class 1 All on deck, class 1.4S in holds</p>	<p><b>Deck loads</b>  Tanktop 15.0 mt/m<sup>2</sup>  Tween deck pontoons 3.0 mt/m<sup>2</sup>  Hatch covers (HC) 3,5 mt/m<sup>2</sup>  HC between cranes 4,0 mt/m<sup>2</sup></p> <p><b>Hatch cover/Tween deck</b>  Type of hatch covers Hydraulic folding + pontoons  Tween deck pontoons 17 removable pontoons (can be used as bulkheads)</p> <p><b>Propulsion/Manoeuvring</b>  Main Engine 7.200 kW  Bow thruster 650 kW  Propeller Variable pitch propeller  Rudder Free-hanging flap type  Service speed 13,75 kn</p> <p><b>Bunkers/Ballast capacity</b>  Heavy fuel oil 719 m<sup>3</sup>  Marine gas oil 318 m<sup>3</sup>  Lubricating oil 29 m<sup>3</sup>  Fresh water 136 m<sup>3</sup>  Ballast water 5701 m<sup>3</sup></p> <p><b>Cargo gear</b>  Cranes on port side 2 x NMF 250 mt SWL  Load/Outreach 250 mt/6,5-12,0 m  200 mt/5,5-15,0 m  150 mt/5,5-20,0 m  100 mt/4,0-30,0 m  35 mt/3,0-30,0 m  Tandem operation 500 mt SWL</p> <p>Lifting beam on board 1 x 18,0 m, WLL 460 mt  Spreader beams on board 1 x 12,0 m, WLL 250 mt  2 x 3,0-9,0 m, WLL 250 mt  1 x 20' automatic spreader</p> <p><b>Lifting heights</b>  At 6,5 m outreach 34,0 m  At 12,0 m outreach 33,0 m  At 15,0 m outreach 31,6 m  At 20,0 m outreach 28,2 m  At 30,0 m outreach 12,4 m</p> <p><i>All details are believed to be correct but without guarantee/hws.</i></p> <p>Phone: +45 70 70 13 11  E-mail: <a href="mailto:europa@ocean7projects.com">europa@ocean7projects.com</a>  Web: <a href="http://ocean7projects.com">http://ocean7projects.com</a></p>
------------------------------------------------------------------------------------------------------------------------------------------------------------------------------------------------------------------------------------------------------------------------------------------------------------------------------------------------------------------------------------------------------------------------------------------------------------------------------------------------------------------------------------------------------------------------------------------------------------------------------------------------------------------------------------------------------------------------------------------------------------------------------------------------------------------------------------------------------------------------------------------------------------------------------------------------------------------------------------------------------------------------------------------------------------------------------------------------------------------------------------------------------------------------------------------------------------------------------------------------------------------------------------------------------------------------------------------------------------------------------------------------------------------------------------------------------------------------------------------------------------------------------------------------------------------------------------------------------------------------------------------------------------------------------------------------------------------------------------------------------------------------------------------------------------------------	-----------------------------------------------------------------------------------------------------------------------------------------------------------------------------------------------------------------------------------------------------------------------------------------------------------------------------------------------------------------------------------------------------------------------------------------------------------------------------------------------------------------------------------------------------------------------------------------------------------------------------------------------------------------------------------------------------------------------------------------------------------------------------------------------------------------------------------------------------------------------------------------------------------------------------------------------------------------------------------------------------------------------------------------------------------------------------------------------------------------------------------------------------------------------------------------------------------------------------------------------------------------------------------------------------------------------------------------------------------------------------------------------------------------------------------------------------------------------------------------------------------------------------------------------------------------------------------------------------------------------------------------------------------------------------------------------

PROFILE VIEW - BALE CAPACITY

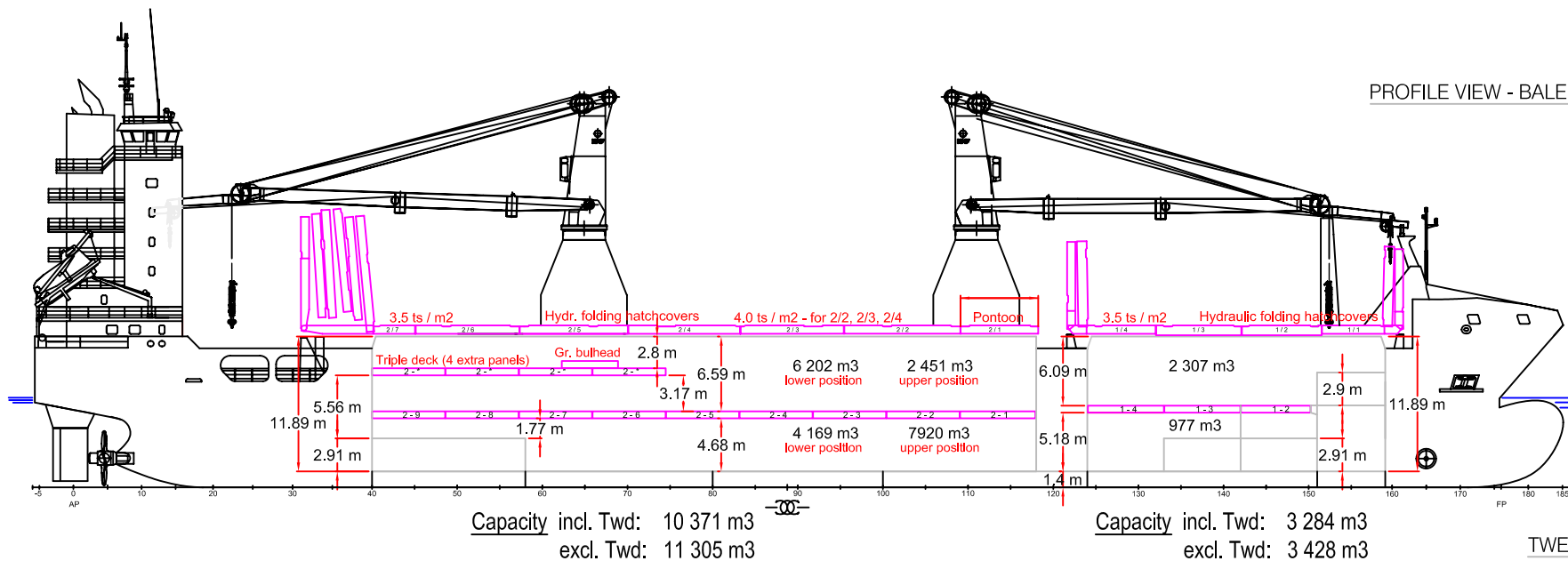

TWEEN DECKS

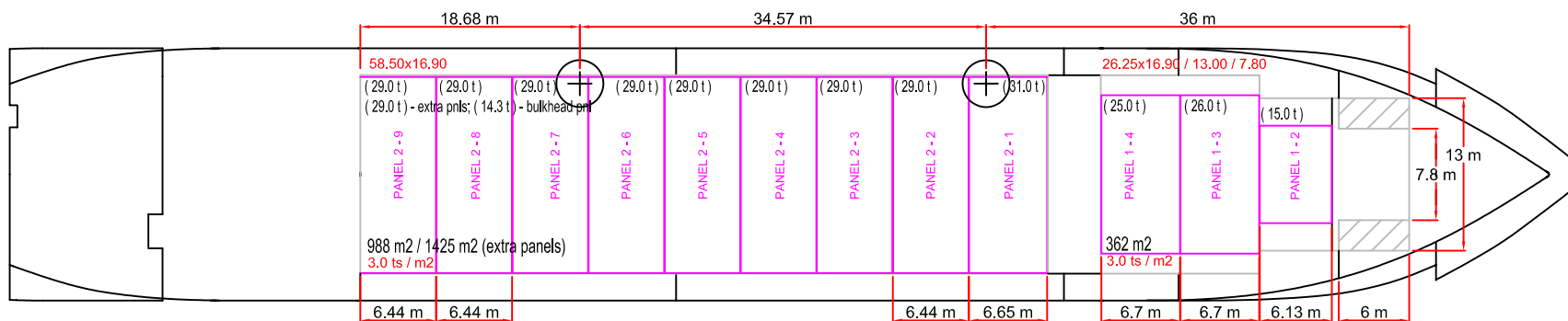

TANKTOP

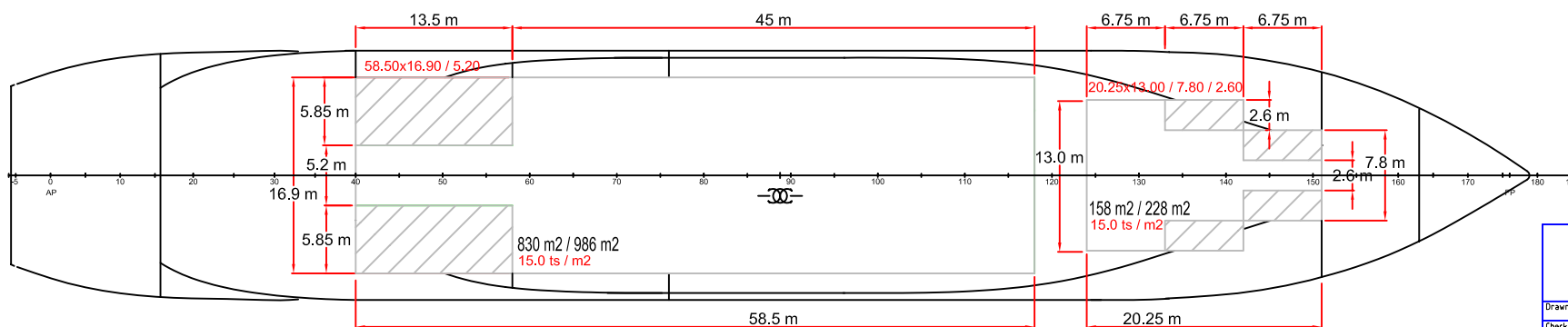

Title: <b>Infosheet R-Type</b>			
Status:			
Drawn by: RT	Date: 04.09.2012	Req by: RS	
Checked by: OS	Date: 04.09.2012		
Scale: NTS	Format: A4	Sht: 1 Of: 2	Drawing Number: <b>12-R0-INFO</b>

## CONTAINER ARRANGEMENT

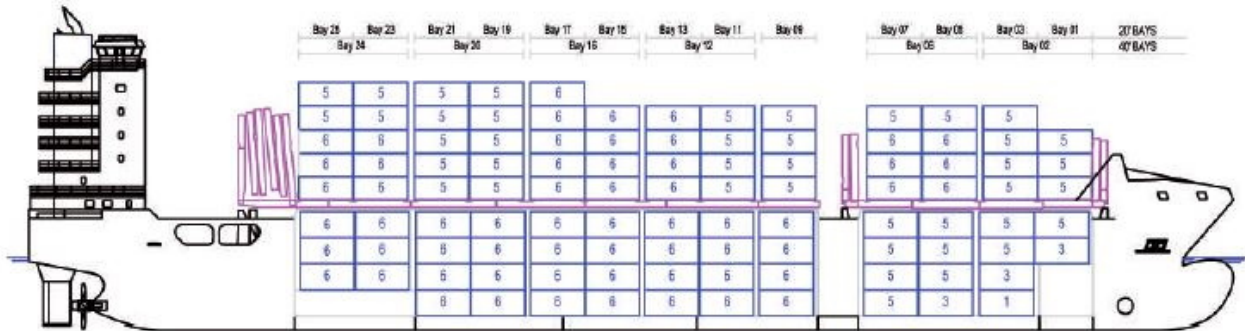

## LIFTING DIAGRAM

CRANE No.1,2 SWL 250 mt

