



## M/V 'KOGA REVOLUTION

Valid as 27 Dec 2023

|                           |  |                                 |  |
|---------------------------|--|---------------------------------|--|
| <b>Registration</b>       |  | <b>Deck loads</b>               |  |
| Call sign                 | D5AH2  | Tanktop                         | 15,0 mt/m <sup>2</sup>   |
| IMO number                | 9267742  | Tween deck pontoons             | 3,0 mt/m <sup>2</sup>  |
| Port of registry          | Monrovia   | Hatch covers (HC)               | 3,5 mt/m <sup>2</sup>  |
| Flag state                | Liberia  | HC between cranes               | 4,0 mt/m <sup>2</sup>  |
| Shipyard                  | Volharding Shipyards   |                                 |  |
| Year/Place of delivery    | 2005/Hoogezand   | <b>Hatch cover/Tween deck</b>   |  |
| Class                     | DNV-GL   | Type of hatch covers            | Hydraulic folding + pontoons   |
| Class notation            | ☒ 100 A5 Multi-Purpose<br>DC-ship Equipped for carriage<br>of cont. DBC, SOLAS-II-2,<br>Reg.19 ERS IW Strengthened<br>for heavy cargo ☒ MC AUT | Tween deck pontoons             | 17 removable pontoons<br>(can be used as bulkheads)  |
| P&I Club                  | Skuld  | <b>Propulsion/Manoeuvring</b>   |  |
| <b>Tonnage</b>            |  | Main Engine                     | 7.200 kW   |
| DWAT                      | 10.581 mt  | Bow thruster                    | 650 kW   |
| DWCC                      | Abt. 9.500 mt  | Propeller                       | Variable pitch propeller   |
| Gross tonnage             | 8963   | Rudder                          | Free-hanging flap type   |
| Net tonnage               | 4522   | Service speed                   | 13,75 kn   |
| <b>Dimensions</b>         |  | <b>Bunkers/Ballast capacity</b> |  |
| Length over all           | 134,65 m   | Heavy fuel oil                  | 719 m <sup>3</sup>   |
| Length between p.p.       | 125,67 m   | Marine gas oil                  | 318 m <sup>3</sup>   |
| Breadth over all          | 21,50 m  | Lubricating oil                 | 29 m <sup>3</sup>  |
| Breadth moulded           | 21,50 m  | Fresh water                     | 136 m <sup>3</sup>   |
| Summer draught            | 7,95 m   | Ballast water                   | 5843 m <sup>3</sup>  |
| Depth moulded             | 9,30 m   | <b>Cargo gear</b>               |  |
| Height keel to top mast   | 40,80 m  | Cranes on port side             | 2 x NMF 250 mt SWL   |
| <b>Hold/hatch sizes</b>   |  | Load/Outreach                   | 250 mt/6,5-12,0 m<br>200 mt/5,5-15,0 m<br>150 mt/5,5-20,0 m<br>100 mt/4,0-30,0 m<br>35 mt/3,0-30,0 m |
| Number of holds/hatches   | 2/2  | Tandem operation                | 500 mt SWL   |
| Hold capacities           | About 13.875 m <sup>3</sup> /489.995 ft <sup>3</sup>   | Lifting beam on board           | 1 x 18,0 m, WLL 460 mt   |
| #1 Lower hold dimensions  | 20,25 x 13,00/7,80/5,20 m  | Spreader beams on board         | 1 x 11,6 m, WLL 250 mt<br>2 x 1,0/2,0/3,0/4,0/5,0/6,0 m<br>(14 in total) WLL 250 mt                  |
| #1 Tween deck dimensions  | 20,25 x 13,00/7,80 m   |                                 |  |
| #1 Hatch dimensions       | 25,50 x 16,90/13,00 m  | <b>Lifting heights</b>          |  |
| #1 Tank top -> TWD -> HC  | 5,18 / 6,09 m  | At 6,5 m outreach               | 34,0 m   |
| #2 Lower hold dimensions  | 58,50 x 16,90/5,20(aft 13,5m)  | At 12,0 m outreach              | 33,0 m   |
| #2 Tween deck dimensions  | 58,50 x 16,90 m  | At 15,0 m outreach              | 31,6 m   |
| #2 Hatch dimensions       | 57,98 x 16,90 m  | At 20,0 m outreach              | 28,2 m   |
| #2 Tank top -> TWD -> HC  | 4,68/6,59 or 8,47/2,80 m   | At 30,0 m outreach              | 12,4 m   |
| Weather deck dimensions   | 89,25 x 17,3 m   |                                 |  |
| Hold height               | 11,89 m  |                                 |  |
| Hatch cover surface       | 1.413 m <sup>2</sup>   |                                 |  |
| Tween deck surface        | 1.736 m <sup>2</sup>   |                                 |  |
| Lower hold surface        | 1.006 m <sup>2</sup>   |                                 |  |
| <b>Container capacity</b> |  |                                 |  |
| Hold capacity             | 252 TEU  |                                 |  |
| Deck capacity             | 295 TEU (10 Reefer)  |                                 |  |
| Total                     | 547 TEU (464 TEU @ 14 mt)  |                                 |  |
| Stack weight TEU/FEU      | Tank top: 90/120 mt<br>Hatch cover: 40/60 mt   |                                 |  |
| TEU slots for IMO class 1 | All on deck, class 1.4S in holds   |                                 |  |

*All details are believed to be correct but without guarantee/HWS*

Phone: +45 70 70 13 11  
E-mail: [europa@ocean7projects.com](mailto:europa@ocean7projects.com)  
Web: <http://ocean7.projects.com>

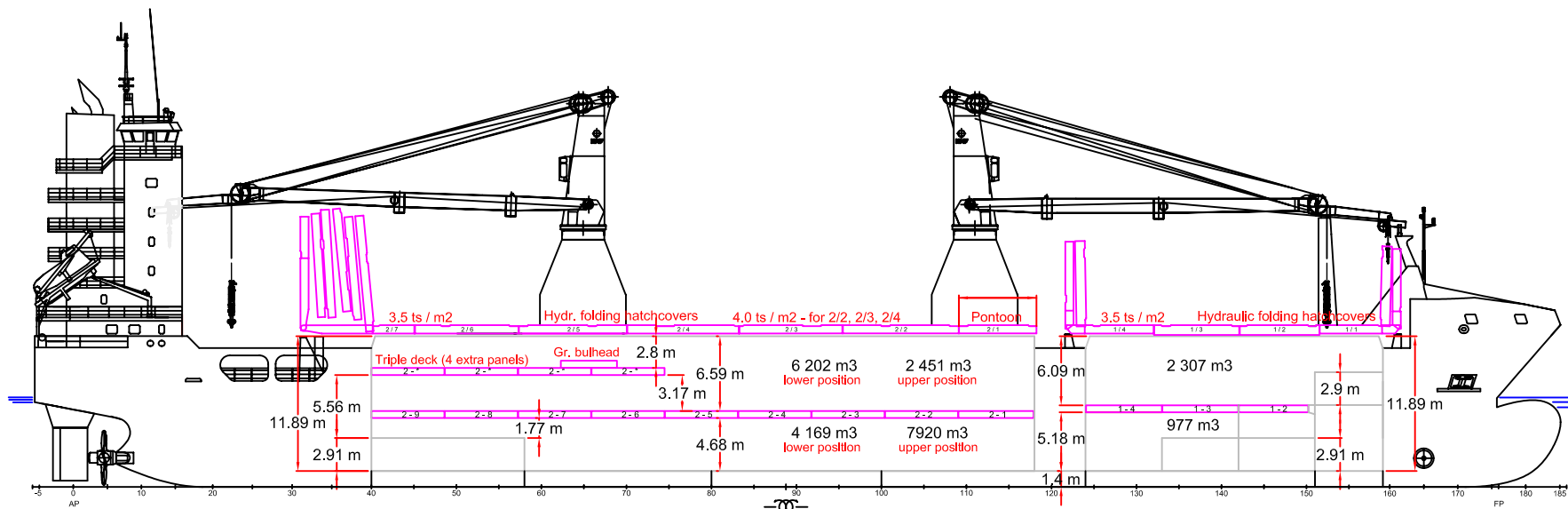

Capacity incl. Twd: 10 371 m<sup>3</sup>  
excl. Twd: 11 305 m<sup>3</sup>

Capacity incl. Twd: 3 284 m<sup>3</sup>  
excl. Twd: 3 428 m<sup>3</sup>

TWEEN DECKS

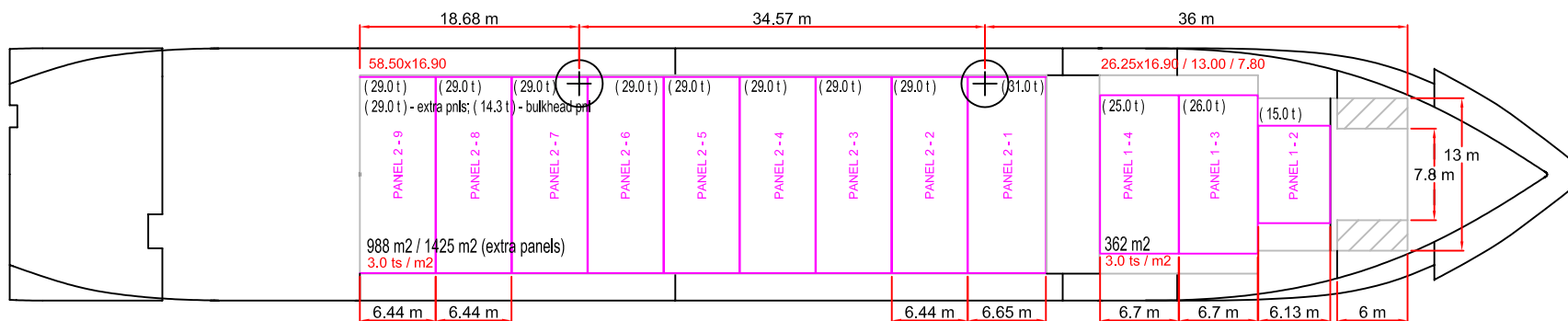

TANKTOP

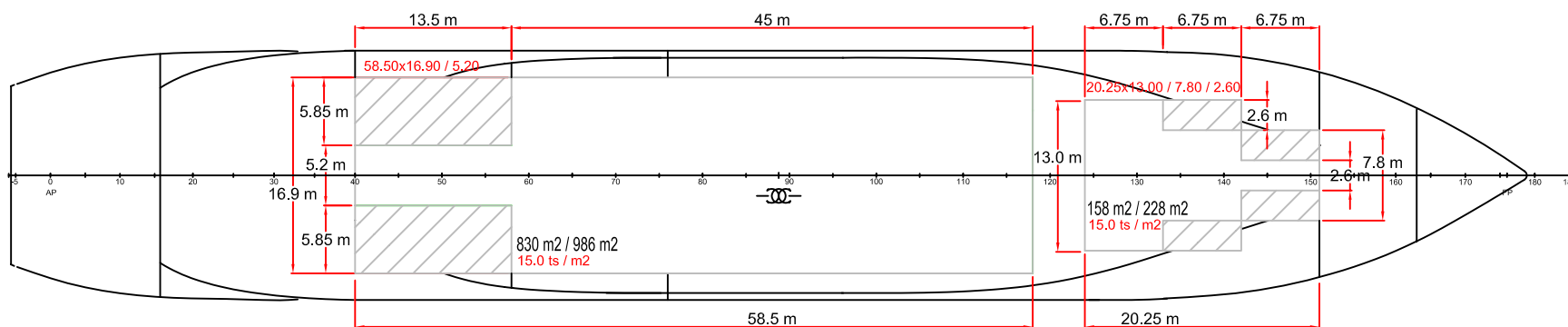

### CONTAINER ARRANGEMENT

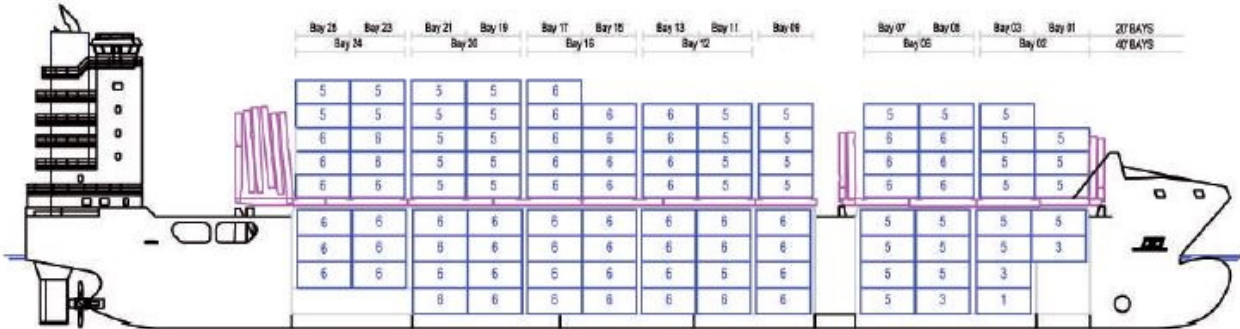

### LIFTING DIAGRAM

CRANE No.1,2 SWL 250 mt

