

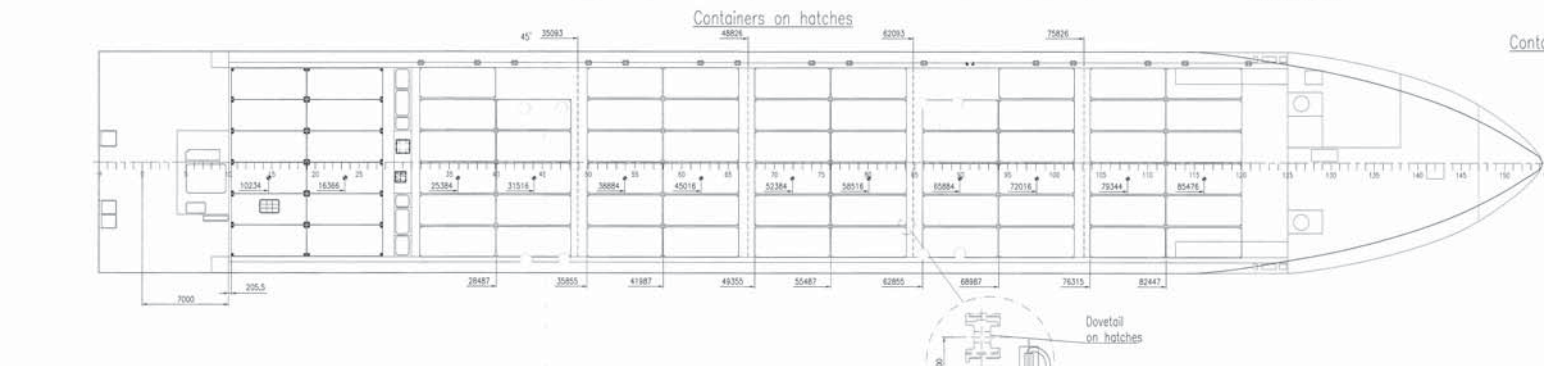

M/V 'O7 LAFITE'

Valid as of 09 Oct 2023

<p>Registration Call sign V2HP5 IMO number 9534482 Port of registry St. John's Flag state Antigua & Barbuda Shipyard Peters Shipyard B.V. Year/Place of delivery 2013/Nn Class DNV Class notation ✱ 1A Multi-purpose dry cargo ship BIS Container EO Strengthened(IB) TMON(oil lubricated)</p> <p>P&I Club Gard</p> <p>Tonnage DWAT 10.049 mt DWCC Abt. 9.400 mt Gross tonnage 6693 Net tonnage 3441</p> <p>Dimensions Length over all 116,26 m Length between p.p. 112,76 m Breadth over all 17,80 m Breadth moulded 17,80 m Summer draught 7,82 m Depth moulded 10,50 m Height keel to top mast 30,50 m</p> <p>Hold/hatch sizes Number of holds/hatches 1/1 Hold capacity About 12.415 m³/438.431 ft³ Lower hold dimensions 70,48 x 15,20 m (narrow fwd) Tween deck dimensions 70,48 x 15,20 m (narrow fwd) Hatch cover dimensions 70,48 x 15,20 m</p> <p>Hold height 11,79 m Tanktop -> Tween deck 6,15 m Tween deck -> Hatch cover 4,84 m T/D 6-9 additional TT->TD 3,23 m TD->HC 7,80 m</p> <p>Hold floor surface 1.049 m² Tween deck surface 1.071 m²</p> <p>Container capacity Hold capacity 232 TEU Deck capacity 172 TEU (no reefer) Total 404 TEU Stack weight TEU/FEU Tanktop: 96/122 mt Hatchcovers: 21/42 mt</p> <p>TEU slots for IMO class 1.1-1.6 On deck only (except ab. E/R) 1.4S On deck and hold</p>	<p>Deck loads Tanktop 18,0 mt/m² Tween deck pontoons 3,5 mt/m² Hatch covers 2,6 mt/m²</p> <p>Hatch covers/Tween deck Type of hatch covers 8 pontoons Tween deck pontoons 12 pontoons, capable of making 7 horizontal divisions</p> <p>Propulsion/Maneuvering Main Engine 4.000 kW Bow thruster 450 kW Propeller Variable pitch propeller Rudder Balanced Service speed 12,0 kn</p> <p>Bunkers/Ballast capacity Heavy fuel oil 568 m³ Marine gas oil 69 m³ Fresh water 95 m³ Ballast water 3984 m³</p> <p>Cargo gear Cranes on port side 2 x hydraulic x 80 mt SWL Load/Outreach 80 mt/3,0-14,0 m 55 mt/3,0-20,0 m 40 mt/2,5-24,0 m</p> <p>Tandem load 150 mt SWL Lifting beam on board 1 x 11,80 m x 145 mt WLL Connectable beams 2 x 4,39 m x 145 mt WLL</p> <p>Lifting heights At 3,0 m outreach 31,2 m At 14,0 m outreach 18,0 m At 20,0 m outreach 18,4 m At 24,0 m outreach 11,2 m</p> <p><i>All details are believed to be correct but without guarantee/HWS</i></p> <p>Phone: +45 70 70 13 11 E-mail: europe@ocean7projects.com Web: ocean7projects.com</p>
--	---

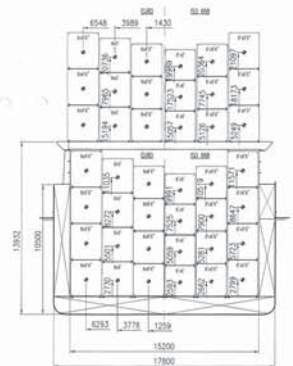
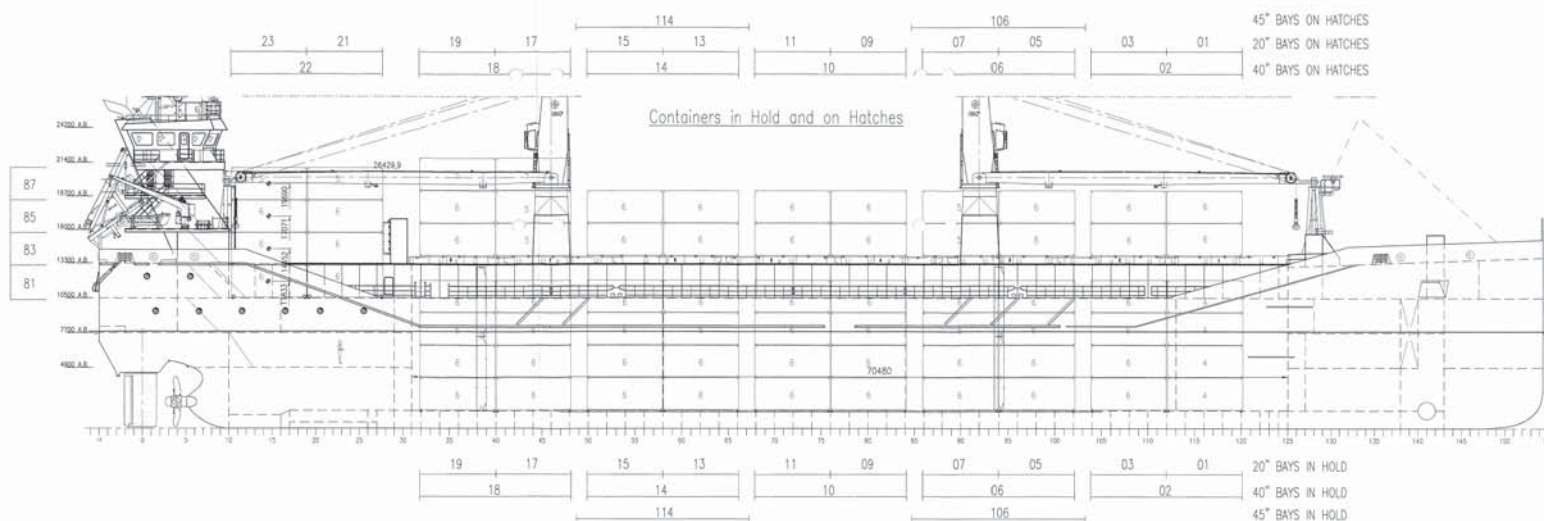

Container Pockets used in Hold

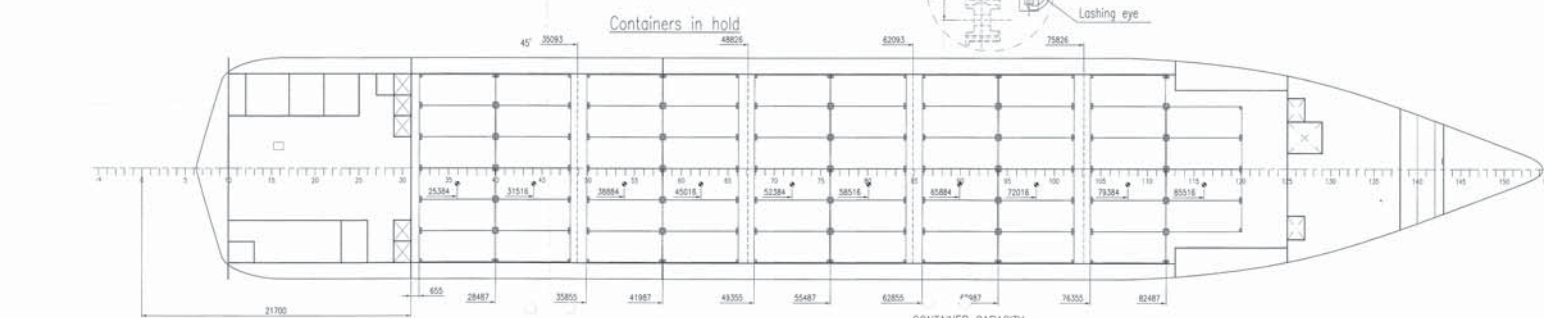
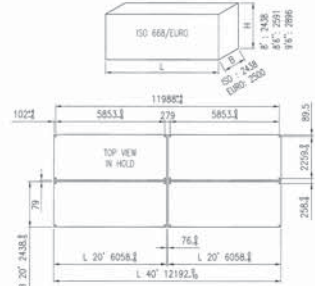

CONTAINER CAPACITY

Container Positions	A-only 20'		B-comb 40'x20'		C-comb 45'x40'x20'	
	20'	40'	20'	45'	40'	20'
TIER 02	58	28	2	12	16	2
TIER 04	58	28	2	12	16	2
TIER 06	58	28	2	12	16	2
TIER 08	58	28	2	12	16	2
TOTAL IN HOLD	232	112	8	48	64	8
TIER 82	58	28	2	11	17	2
TIER 84	58	28	2	11	17	2
TIER 86	10	5	0	0	0	0
TOTAL ON HATCHES	126	61	4	22	34	4
TIER 81	12	6	0	0	6	0
TIER 83	12	6	0	0	6	0
TIER 85	12	6	0	0	6	0
TIER 87	10	5	0	0	5	0
TOTAL ON AFT	46	23	0	0	23	0
TOTAL OF SHIP	404	196	12	70	121	12

Tanktop load 18 ton/m²
 Container stock load:
 TEU: 96 ton
 FEU: 122 ton

On hatches container line load for stock:
 TEU: 21 ton
 FEU: 42 ton
 See also container lashing manual.

Class: Lloyd's Register
 = 100 AT LMC UMS SCM
 Strengthened for Heavy Cargoes
 Container cargoes in holds and on hatchcovers
 With the descriptive code ECDA (stow)
 SOLAS-II regulation 19
 Flag: Dutch Shipping Inspectorate, unrestricted waters.

SOLE 10000

MAIN PARTICULARS	
Length o/s	ca. 116,360 m
Length (BRKD)	ca. 112,760 m
Length w/l	ca. 112,760 m
Hull length	ca. 112,760 m
Breadth max	ca. 17,80 m
Depth	ca. 10,50 m
Summer draught	ca. 7,80 m
Hold capacity	ca. 12,420 m ³ ca. 438,600 cu ft
Deck loading	ca. 18 t/m ²
Containers in hold	232 TEU (112 FEU + 8 TEU)
Containers on hatch	128 TEU (64 FEU + 4 TEU)
Containers on aft deck	48 TEU (24 FEU)
Tank capacities	
ballast	ca. 3984 m ³
fresh water	ca. 95.8 m ³
Fuel HFO	ca. 589 m ³
Sea Oil	ca. 88.4 m ³
ICE	ca. 6613 GJ
Engine power installed	ca. 3441 kW
	ca. 6000 kW

1) Drawn by	2) Date	3) Scale
4) Checked by	5) Date	6) Scale
7) Approved by	8) Date	9) Scale
10) Drawn by	11) Date	12) Scale
13) Checked by	14) Date	15) Scale
16) Approved by	17) Date	18) Scale
19) Drawn by	20) Date	21) Scale
22) Checked by	23) Date	24) Scale
25) Approved by	26) Date	27) Scale

Title: Container Plan	
Project: SOLE 10000	Hub: 900
Checked: Status: RD Rev: F	TAG: 11-0601

O7 LAFITE

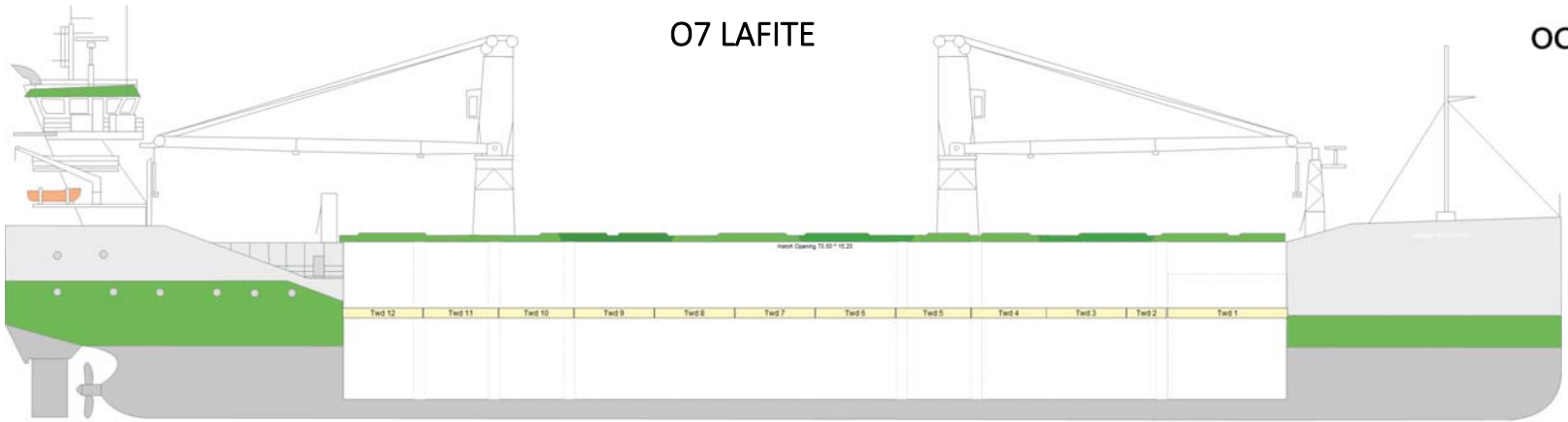

Top view Main Deck

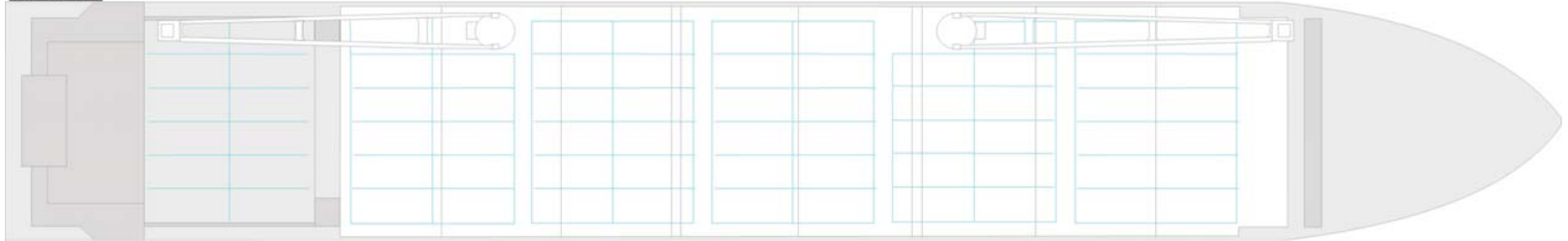

Top view Tweendeck

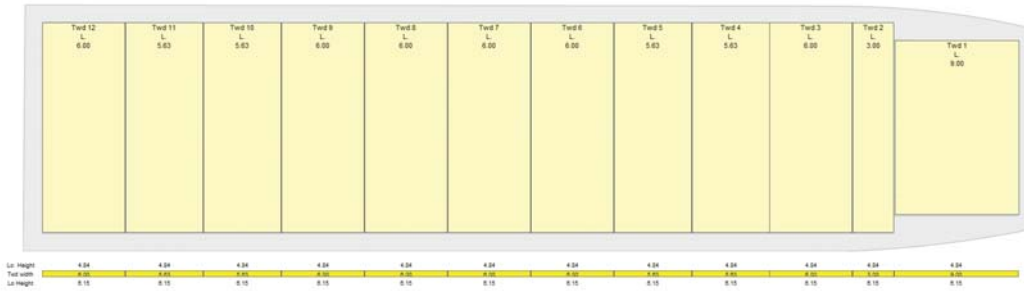

Top view Tank Top

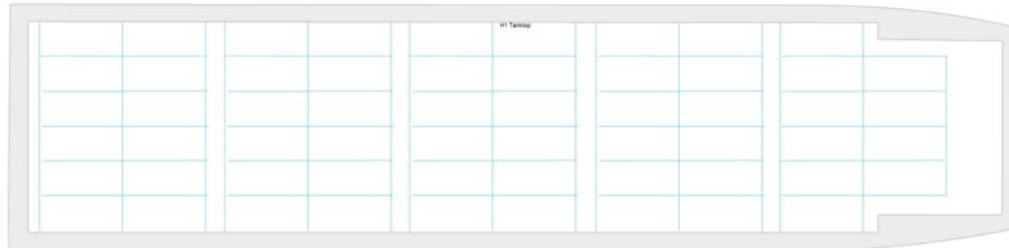

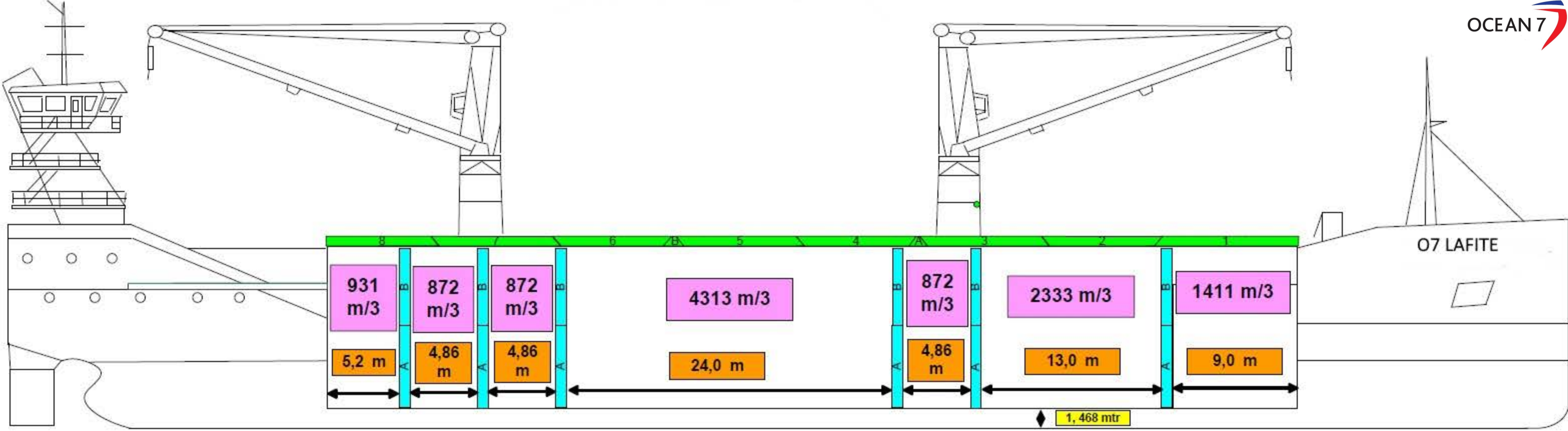

Bulkhead particulars

		Dimensions	Weight	Volume
A	6 pcs	5,97 x 15,14 x 0,76	24,61 tonn	68,96 m³
B	4 pcs	5,595 x 15,14 x 0,76	23,51 tonn	64,63 m³
C	1 pc	2,97 x 15,14 x 0,76	13,21 tonn	34,31 m³
D	1 pc	8,97 x 15,14 x 0,76	28,84 tonn	86,17 m³

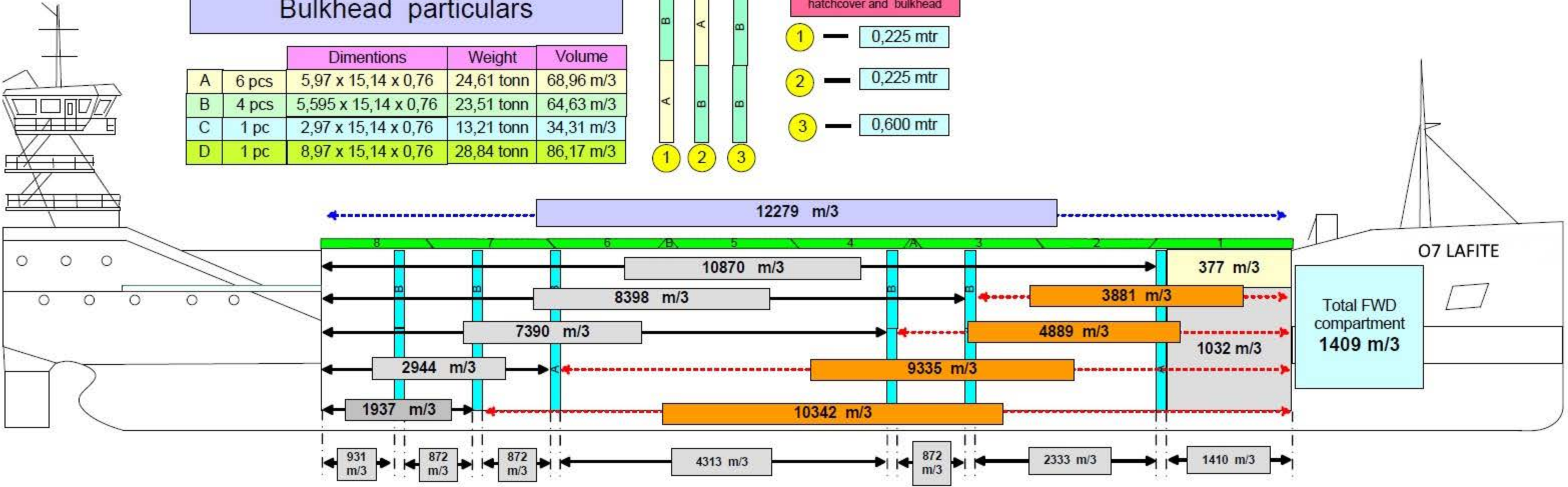
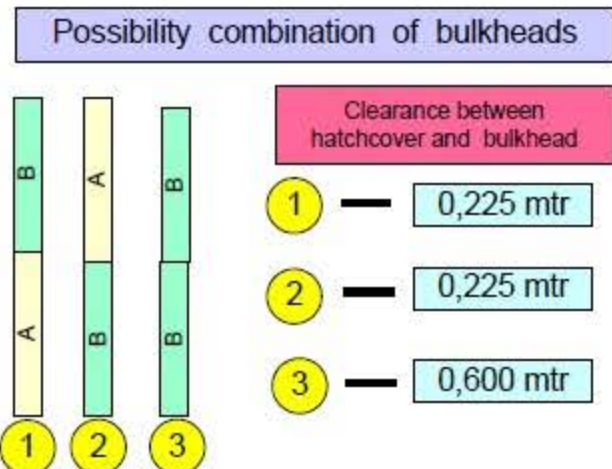

Total VOLUME without any bulkhead = 12415,57 m³

