



M/V 'PACIFICA'

Valid as of 29 Jul 2022

Registration	
Call sign	9V8831
IMO number	9431460
Port of registry	Singapore
Flag state	Singapore
Shipyard	Sanfu Shipyard
Year/Place of delivery	2009/PRC
Class	Korean Register
Class notation	KRS1 – Cargo ship, General Dry Cargo IA Clean1 IWS CDG IHM LG KRM1 – UMA BWT
P&I Club	West of England Ship Owners
Tonnage	
DWAT	12.580 mt
DWCC	Abt. 11.000 mt
Gross tonnage	9.627
Net tonnage	4.261
Dimensions	
Length over all	138,50 m
Length between p.p.	130,71 m
Breadth over all	21,00 m
Breadth moulded	21,00 m
Summer draught	8,00 m
Depth moulded	11,00 m
Height keel to top mast	39,38 m
Hold/hatch sizes	
Number of holds/hatches	3/3
Hold capacity	About 15.953 m ³ /563.375 ft ³
#1 Hatch coaming/Lower hold	18,72 x 15,00/10,00 m
#2 Hatch coaming/Lower hold	42,00 x 17,50 m
#3 Hatch coaming/Lower hold	25,50 x 17,50/14,60 m
Weather deck dimensions	104,05 x 17,50 m
#1, #2 and #3 Hold heights	10,75/11,40/10,99 m
#1 Heights above/below T/D	4,55/5,40 m
#2 Heights above/below T/D	4,43/5,97 m
#3 Heights above/below T/D	4,43/5,56 m
Loading area under deck	2.856 m ²
Loading area on deck	1.463 m ²
Container capacity	
Hold capacity	300 TEU
Deck capacity	300 TEU (no reefer)
Total	600 TEU (basis slots)
Stack weight TEU/FEU	Tanktop: 96/120 mt Hatchcovers: 50/65 mt
TEU slots for IMO class 1.1-1.6	On hatches and hold #1
1.4S	On deck and all holds

Deck loads	
Tanktop	16,0 mt/m ²
#1 + #2 upper tween deck	2,5 mt/m ²
#2 lower/mid tween deck	4,0 mt/m ²
#3 hold	4,0 mt/m ²
Hatch covers	1,75 mt/m ²
Hatch covers/Tween deck	
Type of hatch covers	18 hydr./foldable covers
Tween deck pontoons	3+7+4 = 14 removable panels
Grain bulkheads made of tween deck panels	2 positions in hold #2
Propulsion/Maneuvering	
Main Engine	5400 kW
Bow thruster	500 kW
Propeller	Balanced
Rudder	Controllable Pitch Propeller
Service speed	13,0 kn
Bunkers/Ballast capacity	
Heavy fuel oil	955 m ³
Marine gas oil	152 m ³
Fresh water	148 m ³
Ballast water	4.932 m ³
Cargo gear	
Cranes on port side	2 x NMF x 150 mt SWL
Load/Outreach	150 mt/4,5 – 16,0 m 120 mt/4,5 – 19,0 m 95 mt/4,0 – 24,0 m 70 mt/3,5 – 33,0 m
Tandem load	300 mt SWL
Lifting beam on board	1x18 m 300 WLL
Spreader beams on board	2 of each: 9,5/6,5/3,5 m 150 mt WLL
Lifting heights	

All details are believed to be correct but without guarantee/HWS

OCEAN7 Projects ApS
Jyllandsgade 19A
DK-7000 Fredericia
Denmark

Phone: +45 7070 1311
E-mail: europe@ocean7projects.com

SIDE VIEW

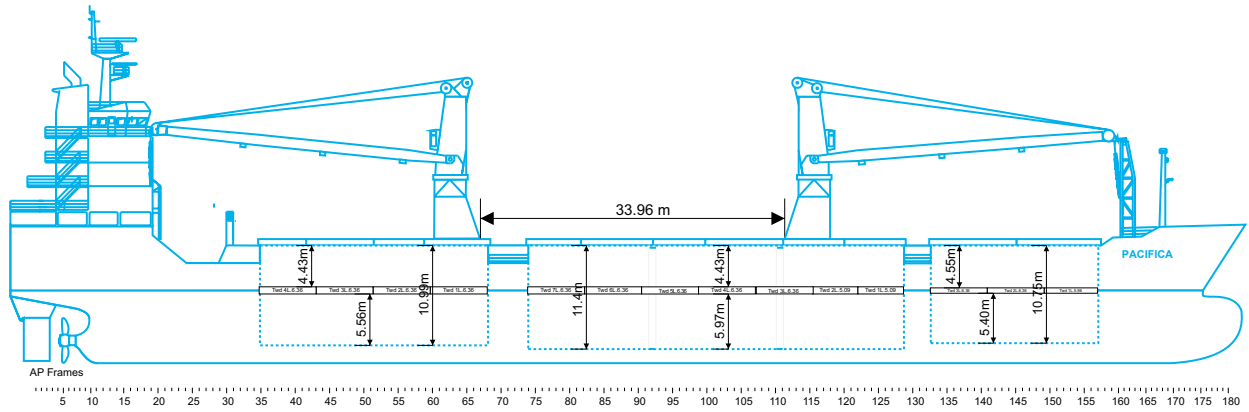

MAIN DECK

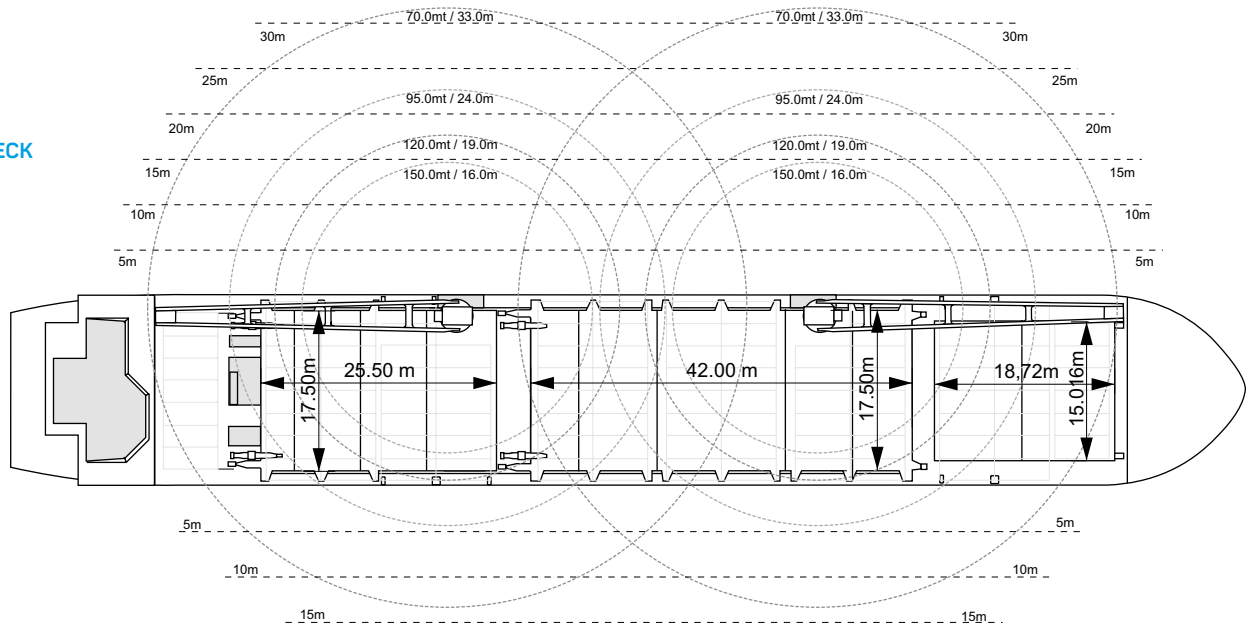

TWEENDECK

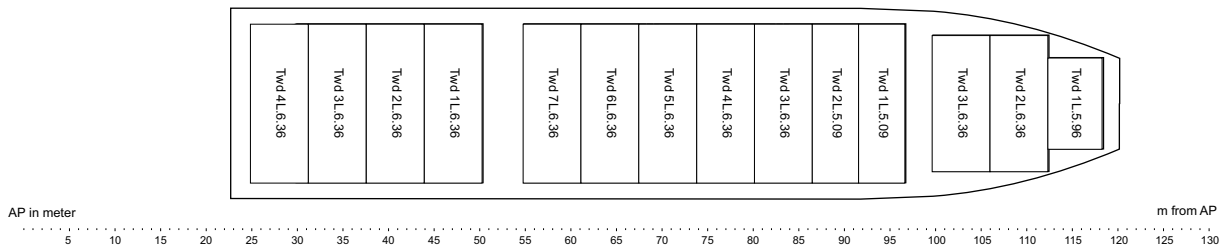

HOLDS & DOUBLE BOTTOM

